

Advanced Engineering

Testing Solutions

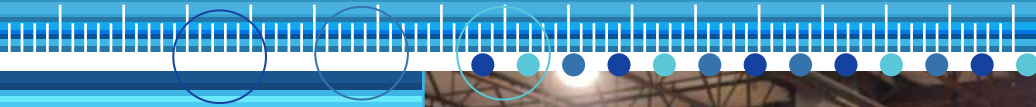

Military Products





Military Vehicle Testing Experts

Mustang Advanced Engineering (MAE) has been a leading provider of comprehensive testing solutions for the development and testing of military engines, powertrain systems and complete military vehicles since its founding in 1975. A division of Mustang International, MAE has long been known as a trusted source of expertise in measurement and testing technologies for military applications. World-class product offerings, custom design support and technical assistance, all backed by a dedicated factory customer service team has positioned MAE among the world leaders in providing advanced testing solutions for military applications.

“Custom Solutions” Approach

MAE’s “custom solutions” approach focuses all of our product, application and automation experience on your specific testing requirements. Our goal is to provide a tailored solution that optimizes our customer’s testing and development operations by providing intelligent system designs coupled with outstanding technical expertise and world-class customer support.

MAE provides specialized testing solutions designed to meet your exact testing requirements for engine, transmission, powertrain, or component and sub-assembly testing applications. MAE’s modular design concept allows for a high degree of scalability, from simple durability testing to highly sophisticated and complex powertrain development test cells.

Engine Dynamometers



Chassis Dynamometers



Transmission Dynamometers



Tow Dynamometers

Global Market Leader

MAE offers a wide range of testing and measurement solutions, custom-tailored to fit your specific testing application. MAE has systems installed in virtually every corner of the globe and provides ongoing technical support and service to an install base of tens of thousands of dynamometer systems worldwide.

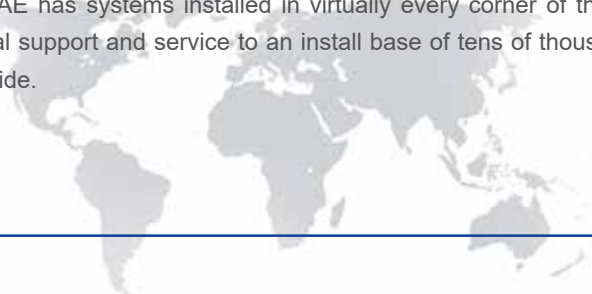



Powertrain test stand enclosed in modular containerized testing facilities supplied to US Military in Iraq.



Multi-Axle Chassis Dynamometer in Extreme Climatic Test Chamber.

“This was my first time dealing with Mustang, but I will say I hope it will not be the last. Speaking for myself, I would not hesitate to recommend Mustang for any future contract.”

- Troy Morris
Deputy QA / Commissioner
Taji National Maintenance Depot
Camp Taji Iraq

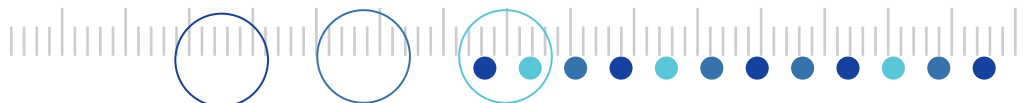



Chassis Dynamometers

MAE has designed and built some of the world's largest and most sophisticated chassis dynamometers for testing multi-axle all-terrain military vehicles. MAE recently completed the design and manufacture of this heavy-duty AC chassis dynamometer and multi-performance tester designed to carry out testing for medium-duty and heavy-duty vehicles with drive axles ranging from one to four, including 8x8, 8x6, 8x4, 6x6, 6x4, 6x2 and 4x4 configurations.

The four axle system features eight chrome-plated 48" rollers that can all be operated independent of one another, cross-coupled, and configured to follow the feedback or command of any roll in the system. The dyne's combined peak full load capacity is 1,600 HP (1,200 kW), combined wheel force is 58,500 lbs (260,000 Newtons) and the maximum wheel speed is an impressive 81 mph (130 kph).

The adjustable wheelbase feature allows each axle to be adjusted independently and gives the dyne the ability to handle vehicle wheelbase ranges from as little as 53 inches to as long as 472 inches (39.3 feet) with an accuracy of less than 2 mm.

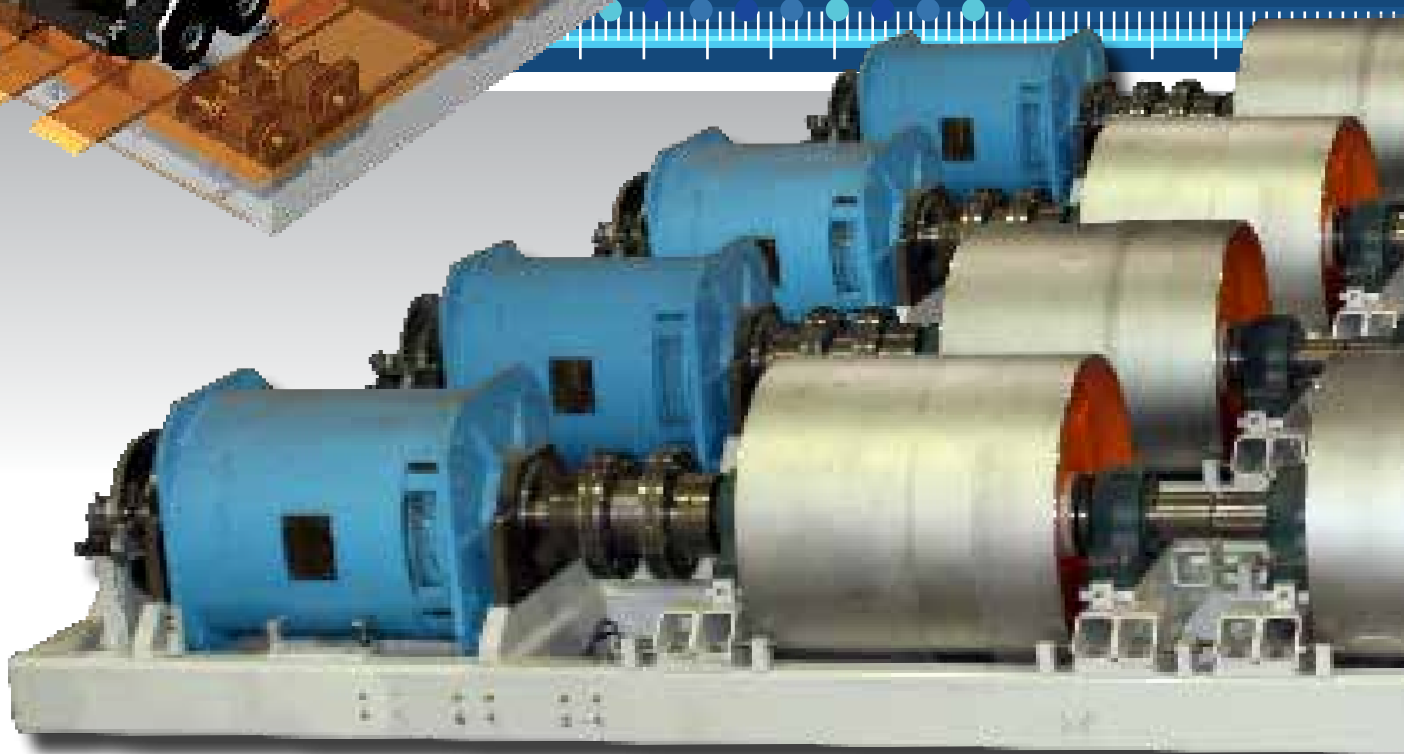
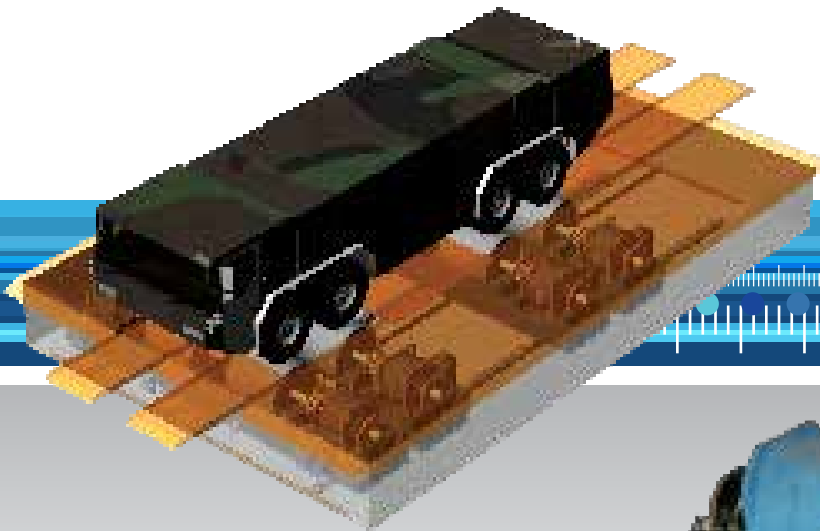



Multi-function End-of-Line Chassis Dynamometer/ABS Brake Tester for MRAP vehicle production validation supplied to Force Protection/Superior Controls.

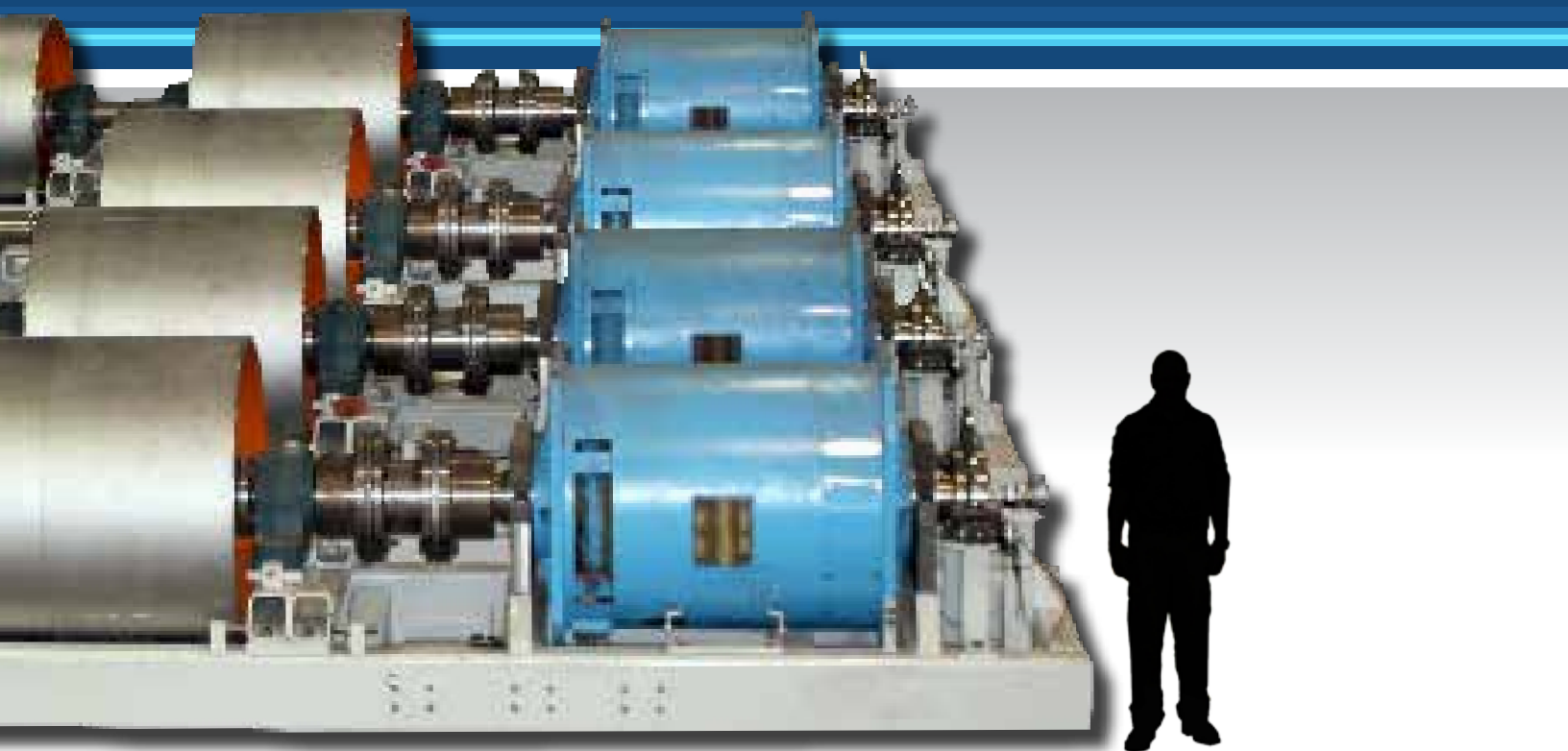



Engine Test Stands



MAE offers an extensive product offering of engine test stand products for a variety of engine testing applications. MAE's product offering is designed to meet fractional to 25,000+ HP and speeds up to 100,000 rpm, with a complete line of controls, data acquisition, engine electronic interface and conditioning modules. MAE offers products from a single engine test stand component to complete custom tailored systems or test labs. MAE's range of standard product offerings includes AC, PM, DC, servo, water-cooled EC, air cooled EC, hybrid AC/EC, water brake, hydraulic clutch plate brakes and other sophisticated loading devices.



Transmission Test Stands

MAE is far and away the industry leader in providing transmission test stands and transmission test cell components. MAE offers products to test light duty, medium duty, heavy duty and extreme heavy duty transmissions. MAE's products are used in advanced research and development labs, prototype labs, production environments, repair and remanufacturing facilities. MAE's transmission test stands operate with a variety of AC, Servo, PM, EC and Hydraulic motors and power absorbers.



Mustang designed, built and delivered this state-of-the-art cross-drive transmission test bench for testing the Abrams M1A1 & M1A2 battle tank's Allison X1100-3B transmissions in accordance with NMWR 9-2520-276 volumes 1 thru 3.



Engine test cell supplied in a modular containerized testing facilities for US Military in Iraq.

Aviation Test Stands

MAE offers a comprehensive line-up of aviation test systems. Engine, transmission, and high-speed gearbox testing have long been a specialty and area of technical expertise for the team of testing and applications engineers at MAE. MAE is widely regarded as a leading global provider of dynamometer systems that require accurate and repeatable inertia simulation, speed control, force control or acceleration control. Mustang's line-up of dynamometer and test systems have evolved and acquired techniques and capabilities resulting from decades of experience in developing "high accuracy" simulation and test systems. Regardless of the unique challenges of your application, MAE has a complete systems solution to meet your testing needs.



Chassis Dynamometers

MAE was built on the tradition of world-class chassis dynamometers. MAE's engineers have designed and manufactured chassis dynamometer test systems for virtually all types of vehicles and applications ranging from independent all-wheel-drive military vehicles to fractional-powered wheeled vehicles and everything in between. MAE has a chassis dynamometer solution for virtually every application, including but not limited to, emissions, NVH, durability, EMC/RFI, wind tunnel, environmental chambers, and racing performance.





Exterior view of containerized test laboratory prior to shipping to US military depot in Iraq.

Production/In-Process Testing



MAE has extensive experience in the field of production/in-process testing and offers a variety of products and services to support your production testing requirements. MAE's engineers will work closely with your team to custom tailor a solution to solve virtually any production testing challenge. MAE has developed systems to handle multi-function vehicle testing, production electronic & wire harness testing, chassis sensor and electronic testing, production engine and transmission testing and many other applications. MAE can upgrade your existing production line hardware and software, interface with existing databases or supply a complete turnkey production testing solution.



Tow Dynamometers

MAE offers the largest and most complete line of tow dynamometers available for test engineers in the industry. Using advanced micro-processor based controls and air-cooled eddy current power absorbers, tow dynamometers are capable of testing vehicles and simulating road profiles taken from pre-recorded data of road grades, hills and mountains without ever having to leave the safe and controlled confines of the flat test track.

Containerized Test Cells

MAE offers a number of modular containerized test cells, from single engine test cells to complete multi-cell test facilities. MAE's containerized test cells are self-contained and fully equipped with all the supply, monitoring and measurement units of a traditional test cell facility. MAE's containerized test cells have many distinct advantages including fast and cost-effective relocation of testing facilities and minimized building modification requirements and expenses.



Controls & Data Acquisition

MAE is a specialist in the design of control systems for testing and production systems. Most of MAE's control systems are configured with data acquisition to operate as industrial controllers known as supervisory control and data acquisition (SCADA) control systems. Database integration and/or connectivity is standard with most of our control systems. In addition to computer controls, MAE supports PLC, PAC, embedded controllers and many other specialized custom control requirements.

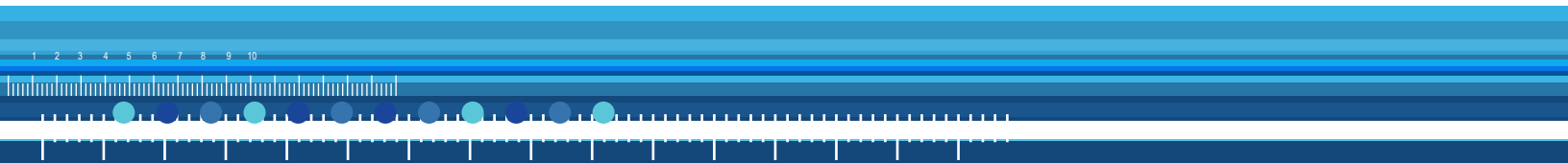



Design & Engineering Support

Much more than the typical dynamometer manufacturer, Mustang has slowly and steadily grown into a highly-diversified, vertically integrated, technology-based engineering firm with world-class design, manufacturing, software, controls, and integration capabilities that position Mustang as a very unique supplier to the industry. In addition to a team of experienced software engineers, mechanical engineers, and electrical engineers who develop all of the company's products and systems in-house, Mustang's versatility and speed are its best strengths.

MAE offers a wide array of services to customers all over the world. Our experienced team of engineers use the latest solid modeling CAD and CAE software and offers a comprehensive resource for your testing design and development needs. Whether your application is fully conceived or you need a design partner, the engineers at Mustang Advanced Engineering invite you to tap into their decades of experience in testing and measurement systems development.

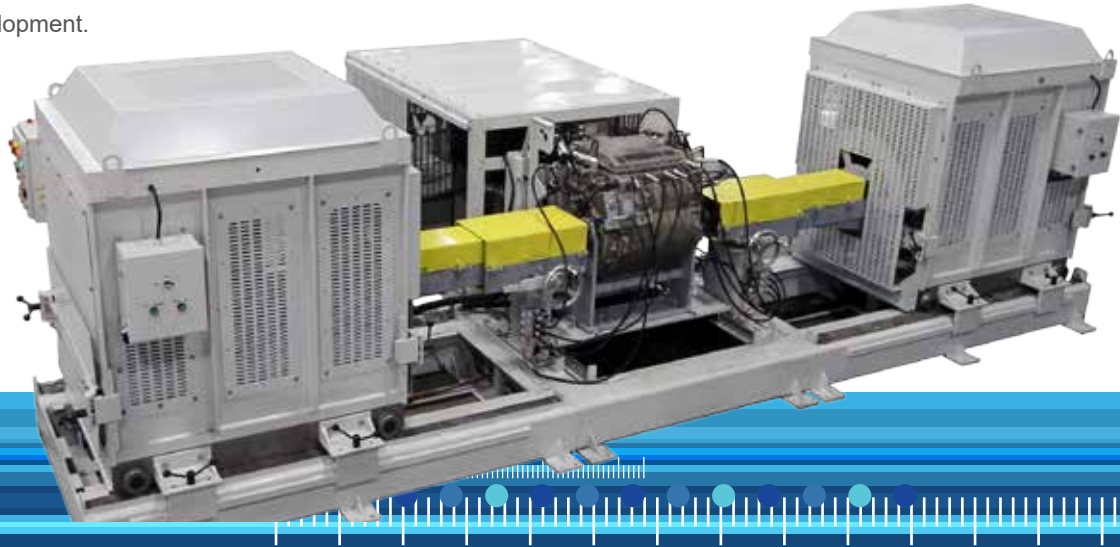

From Concept

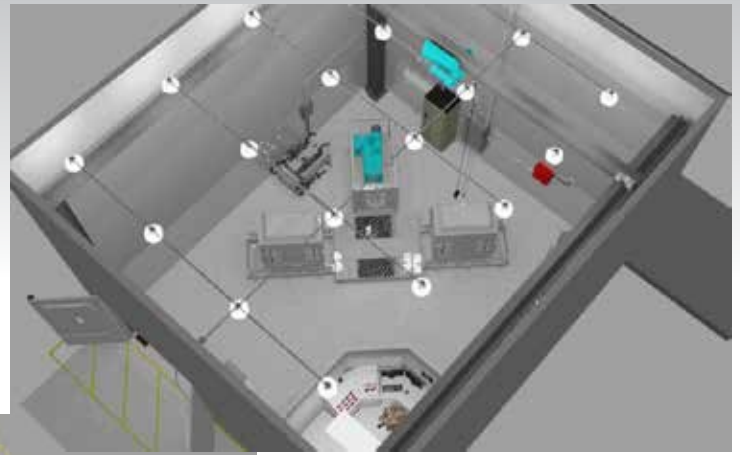
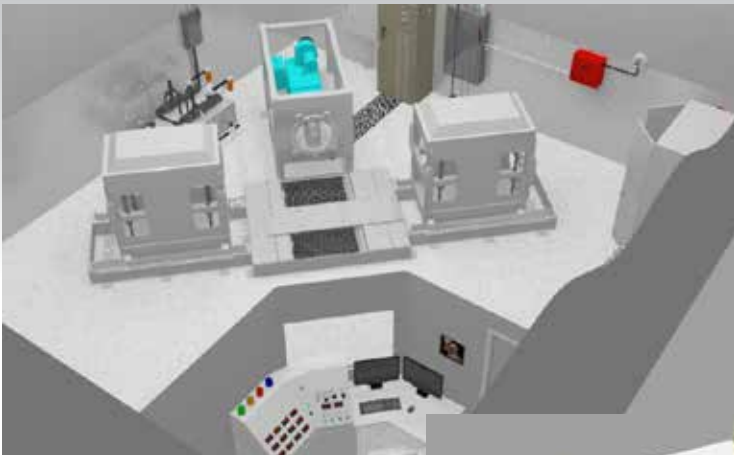

To Engineering

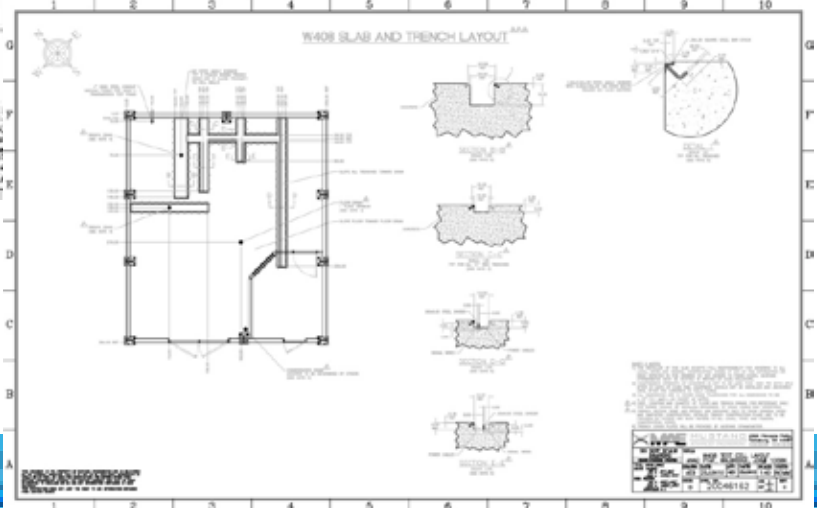
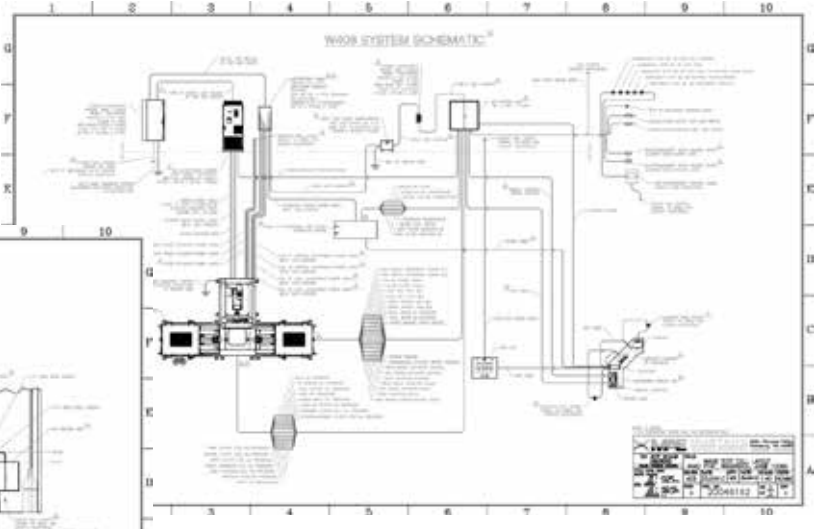
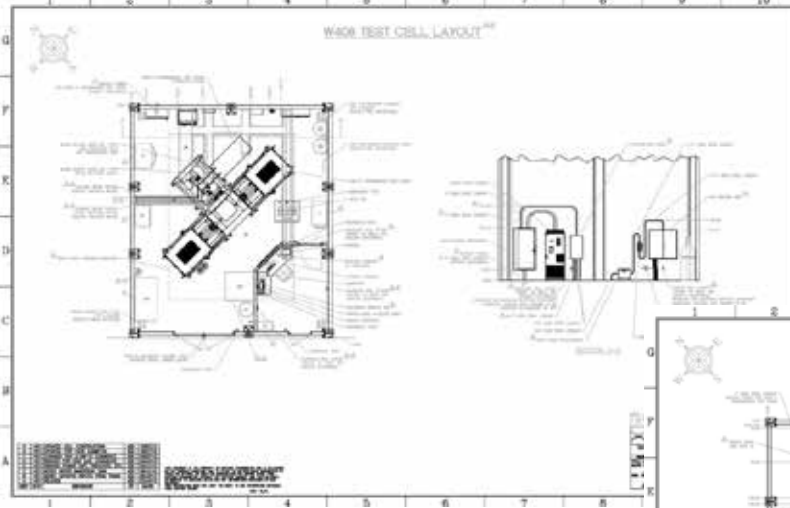

To Project Completion

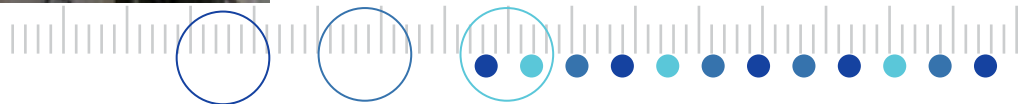



Exterior view of modular transmission test cells installed at Anniston Army Depot

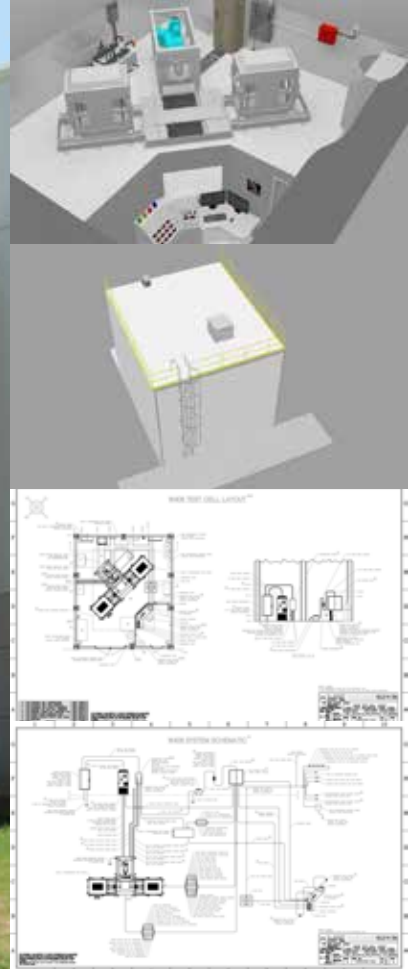

1 2 3 4 5 6 7 8 9 10



Facility Engineering/Integration Services

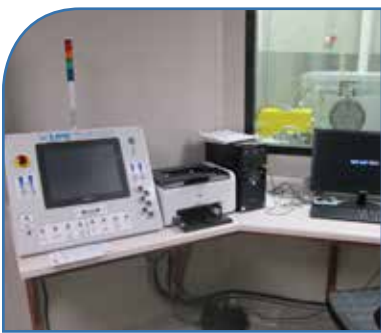

MAE also performs complete facility engineering/integration/installation services including:

- Pre-fabricated facility design and construction
- Control room design and construction
- Cooling tower engineering and installation
- Plumbing
- Electrical
- Fuel delivery systems
- HVAC
- Fire Suppression
- Bed plate
- Crane systems



Upgrades of Existing Equipment

MAE can upgrade virtually any existing test stand regardless of manufacturer. MAE is a vertically integrated company, with full engineering, fabrication, machining, painting, assembly, and test capabilities in house. This allows MAE to upgrade existing test stands to the latest technologies, while using as many existing components as possible. This provides customers with flexibility when new capabilities are required for their testing equipment.



Turn-key Installation Services

Mustang's project management team leaders are experienced in managing extremely large projects where multiple discipline trades and engineering knowledge are required. MAE has a very successful track record when it comes to installing complete testing labs including; bed plates, cranes, control rooms, water cooling towers, pump house systems, supply power transformers, power switch gear, construction drawings, and as-built drawings. MAE installation teams have successfully performed countless large scale operations. One such project required 350 test systems in 110 different locations across multiple state lines and country borders. When your project requires a supplier that has experience and a proven track record for managing large-scale projects, you can count on Mustang Advanced Engineering.





About MAE

Mustang Advanced Engineering is a leading provider of comprehensive testing solutions for the development and testing of engines, powertrain systems and complete vehicles. Founded in 1975, Mustang has long been a trusted source of expertise in measurement and testing technologies for the global industrial market. World-class product offerings, custom design support and technical assistance, backed by a dedicated factory service team, has positioned MAE among the global leaders in providing advanced testing solutions.

ISO 9001:2008 Certified

Offices Worldwide

U.S. Corporate Headquarters
Mustang Advanced Engineering
2300 Pinnacle Parkway
Twinsburg, OH 44087
Phone: (330) 963-5400
Fax: (330) 425-3310
Email: sales@mustangae.com

www.mustangae.com

As a full service supplier/partner, MAE offers a wide array of services to customers all over the world. Working with your staff, our experienced team of engineers uses the latest solid modeling CAD and CAE software and offers a comprehensive resource for your testing design and development needs. Our engineers specialize in finding the most practical and economical solutions for new or unusual testing applications. Whether your application is fully conceived or you need a design partner, the engineers at Mustang Advanced Engineering invite you to tap into their decades of experience in testing and measurement systems development.

Our mission is to achieve the highest possible level of customer satisfaction by providing innovative technical solutions and product designs and by striving to achieve perfection in product quality, delivery and service. At MAE, our customers are our highest priority - we do everything in our power to satisfy our customers. Our entire organization understands that the customer comes first and nothing else is more important.